



U.S. Fire Administration

Home Fire Protection

Residential Fire Sprinkler Systems Save Lives

FA-43 / February 2008



FEMA

Home Fire Protection Residential Fire Sprinkler Systems

Sprinkler Systems in Industry

Schools, office buildings, factories, and other commercial buildings have benefited from fire protection sprinkler systems for over a century. To protect investments in buildings and machinery, the textile mills in New England began using sprinkler systems over 100 years ago following a series of devastating fires that claimed many lives and destroyed entire businesses.

Sprinklers in Homes

But what about our homes? Although we protect our businesses, what actions do we take to protect our families, our homes, and our possessions from fire? Millions of Americans have installed smoke alarms in their homes in the past few decades, but a smoke alarm can only alert the occupants to a fire in the house...it cannot contain or extinguish a fire. Residential sprinkler systems can!

Sprinklers—The Solution

Fires in residences have taken a high toll of life and property. In 2006 there were

- 412,500 residential fires;
- 2,620 civilian fire deaths;
- 12,925 civilian fire injuries; and
- over \$7 billion in property damage.

Data Source: "Fire Loss in the U.S. During 2006," NFPA

Studies by the Federal Emergency Management Agency's (FEMA) U.S. Fire Administration (USFA) indicate that the installation of residential fire sprinkler systems could have saved thousands of lives, prevented a large percentage of those injuries, and eliminated hundreds of millions of dollars in property losses.

Advantages of Newly Designed Home Sprinkler Systems

Fast Response

Residential sprinklers listed by Underwriters Laboratories (UL) are now available. They are designed to respond to a fire much faster than currently available standard commercial and industrial sprinkler systems. The new home sprinklers react automatically to fires more quickly because of their improved sensitivity.

Low Cost

At the present time, cost of a home sprinkler system is targeted at approximately \$1.00 to \$1.50 per square foot in new construction. It is hoped that the cost will decrease as the use of home fire protection grows. It is also possible to retrofit existing homes with sprinkler systems.

Small Size

For residential systems, the sprinklers will be smaller than traditional, commercial, and industrial sprinklers, and can be aesthetically coordinated with any room decor. Sprinklers can be installed flush with walls and ceilings.

Minimal Installation Work

When homes are under construction or being remodeled, a home sprinkler system will require minimal extra piping and labor. Typically, systems are concealed above ceilings and in the walls.

Low Water Requirement

These systems will require less water than the systems installed in industrial or commercial establishments and can be connected to the domestic water supply.

Piping Requirements

The use of plastic pipe has brought down the cost of installation in new construction and the retrofit of existing dwellings.

A Growing Number of Communities Promote Home Fire Sprinklers

The following communities represent a cross-section of jurisdictions that have adopted residential sprinkler ordinances. For a more complete list, refer to the Residential Fire Safety Institute (RFSI) Web site at www.firesafehome.org

- Scottsdale, AZ;
- Cobb County, GA;
- Prince George's County, MD;
- Livermore, CA;
- Long Grove, IL;
- Chapel Hill, NC;
- Germantown, TN; and
- Altamonte Springs, FL.

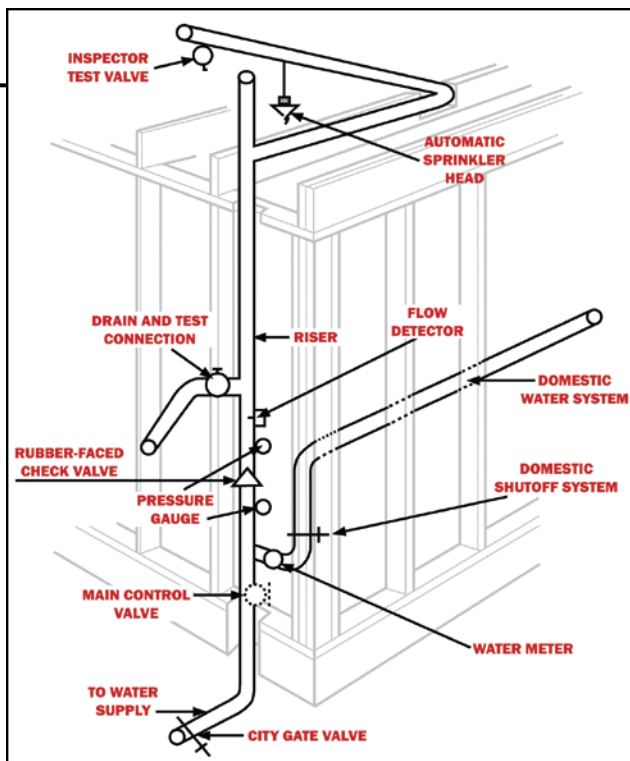

Test Your Home Sprinkler System I.Q.

Here are five statements about home sprinkler systems. Are they true or false?

1. When one sprinkler goes off, all the sprinklers activate.

False! Only the sprinkler over the fire will activate. The sprinkler heads react to temperatures in each room individually. Ninety percent of fires are contained by the operation of one sprinkler.

2. A sprinkler could accidentally go off, causing severe water damage to a home.

False! Records compiled for well over 50 years prove the likelihood of this occurring is very remote. Furthermore, home sprinklers are designed specifically and tested rigorously to minimize such accidents.

3. Water damage from a sprinkler system will be more extensive than fire damage.

False! The sprinkler system will limit a fire's growth severely. Therefore, damage from a home sprinkler system will be much less than the smoke and fire damage if the fire had gone on unabated, or less than the water damage caused by water from firefighting hoselines.

4. Home sprinkler systems are expensive.

False! Current estimates suggest that when a home is under construction, a home sprinkler system costs approximately 1 to 1.5 percent of the total building price.

5. Residential sprinklers are ugly.

False! The traditional, commercial-type sprinklers as well as sprinklers for home use now are being designed to fit in with most any decor.

Sprinklers are a Good Investment for Homebuilders

Through the use of construction tradeoffs, homebuilders and developers can achieve reduced construction costs if residential sprinkler systems are installed.

Home sprinkler systems offer both safety and financial advantages to homebuyers, a rare combination.

Incentives: Who Benefits?

	Developer	Builder
Reduced impact fees	X	X
Increased density	X	
Reduced fire flow	X	
Hydrant spacing increased	X	
Longer access road distance	X	
Longer distance from fire stations	X	
Reduced access to building sides	X	
Narrower streets	X	
Fewer parking restrictions	X	
Longer cul-de-sacs	X	
Reduced turnaround radius	X	
Reduced permit fees		X
Reduced or exempted plan review fees		X
Reduced or exempted fees for field inspections	X	
Reduced fire resistance ratings, no parapet walls	X	
Increased distance to exits		X

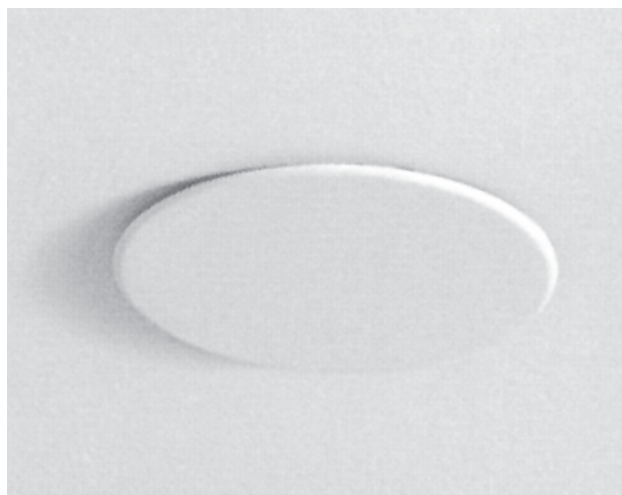

Concealed sprinkler

Sprinklers are a Good Investment for the Homebuyer

- A fire occurs in a residential structure every 79 seconds according to the USFA. To the homebuilder, this fact means that a large share of potential customers now have knowledge of the terror and destruction caused by fire.
- Families with children, senior citizens, and handicapped members have special fire protection needs. Home sprinkler systems provide added protection for these people.
- In case of a home fire, firefighters will have less risk of injury or life loss since they will be fighting a fire of less intensity.
- Allocation of community resources can be improved with the adoption of home sprinkler technology.
- Communities will be able to make better use of available land and thereby increase their tax base.

Insurance Discount

Insurance from homeowner underwriters will vary, depending on type of coverage. The discounts now range between 5 and 15 percent, with a projected increase in available discounts.

The Move Toward Home Sprinkler Systems

The USFA's research in home fire sprinkler systems successfully focused on systems that would be low cost, fast acting, and reliable. As a result, residential fire sprinklers have gained increased acceptance.

In November 1980, the National Fire Protection Association (NFPA) adopted NFPA 13D, *Standard for the Installation of Sprinkler Systems in One- and Two-Family Dwellings and Manufactured Homes*. The Standard is based on

technical data from the comprehensive full-scale fire tests that were sponsored by the USFA.

Residential Sprinkler Program

Dedicated to reducing this Nation's staggering loss of life and property caused by fire, the USFA has joined with private industry and the fire service to advance the development of residential sprinklers. Since 1976, the USFA has promoted research studies, development and testing, and demonstrations of residential sprinkler systems.

Working with the USFA are

American Fire Sprinkler Association
 Center for Campus Fire Safety
 Consumer Product Safety Commission
 Factory Mutual Research
 Home Fire Sprinkler Coalition
 Home Safety Council
 International Association of Fire Chiefs
 Lubrizol Advanced Materials, Inc.
 NIST/Center for Fire Research
 National Association of State Fire Marshals
 National Electrical Manufacturers Association
 National Fire Protection Association
 National Fire Sprinkler Association
 Operation Life Safety
 Polyurethane Foam Association
 Residential Fire Safety Institute
 Sleep Products Safety Council
 Society of Fire Protection Engineers
 Tyco
 U.S. Department of Housing and Urban Development (HUD)
 Underwriters Laboratories, Inc.
 University of Maryland
 Uponor/Wirsbo
 Worcester Polytechnic Institute, and many others

For more information or copies of this publication, please contact:

U.S. Fire Administration
 16825 South Seton Avenue
 Emmitsburg, Maryland 21727
 800-561-3356
www.usfa.dhs.gov

FA-43/February 2008